

**WCSEE T300 + (T3HP FOR HIRE)**

**INSTALLATION, OPERATION &  
MAINTENANCE MANUAL**

## TABLE OF CONTENTS

<b>1. SAFETY</b> .....	<b>4</b>
1.1. Health and safety at work act 1974.....	4
1.2. General health and safety.....	4
1.3. Leptospirosis.....	4
1.4. Sensible Precautions.....	5
1.5. Vaccinations.....	5
<b>2. Warranty</b> .....	<b>5</b>
2.1. T300 tank enclosures.....	5
<i>WCSEE Ltd will provide a 12 month warranty period for the external &amp; internal structure of the tank.....</i>	<i>5</i>
2.2. M&E installation.....	6
2.3. Warranty limitations and exemptions.....	6
2.4. Chargeable non warranty work.....	6
<b>3. Risk assessment</b> .....	<b>7</b>
3.1. Introduction.....	7
3.1.1 Installation Design Considerations.....	7
3.1.2 Installation and positioning.....	8
3.1.3 Maintenance.....	8
<b>4. Introduction</b> .....	<b>9</b>
4.1. T300 Tank – Showing Top Level Access.....	10
4.2. T3HP Tank – For Hire.....	11
<b>5. PLANT OPERATION</b> .....	<b>12</b>
5.1. TIMER (applicable to 2023 models tanks).....	13
5.1.1. Timer Set Up.....	13
5.1.2. General Requirements.....	15
5.1.3. Electrical Connections.....	15
<b>6. ROUTINE MAINTENANCE</b> .....	<b>16</b>
6.1. Weekly.....	16
6.2. Six Monthly.....	16
6.3. Annually.....	16
<b>7. PROBLEM SOLVING</b> .....	<b>17</b>
7.1. Poor Effluent.....	17

7.2. *Blower not Running* ..... 17  
     Power cut ..... 17  
     Power supply fault..... 17  
     Blower overload has tripped ..... 17  
     Blower runs intermittently ..... 17

7.3. *No air bubbles showing on the surface of the filter section*..... 17  
     Blower not running ..... 17  
     Blower running ..... 17

7.4. *Blockages*..... 17  
     Level in sections is higher than normal ..... 17

7.5. *Smell* ..... 18  
     Smell escaping from the covers on the plant..... 18  
     Smell escaping from the kiosk..... 18  
     Plant smells ..... 18

7.6. *POOR AIR DISTRIBUTION OVER THE FILTER SECTION* ..... 18  
     Blocked air Diffusers..... 18  
     Filter media partially blocked by excessive biomass ..... 18  
     Filter media partially blocked with sludge ..... 18

**8. PLANT START UP** ..... **19**

    8.1. *Introduction*..... 19

    8.2. *Start Up* ..... 20

    8.3. *Procedure* ..... 20

**9. Decommissioning and transportation** ..... **21**

**Revision table:**

<b>Date</b>	<b>Change description</b>	<b>Owner</b>	<b>Checked</b>	<b>Rev</b>
<b>30/11/2022</b>	Revised manual layout with timers added.	TC	BD	J
<b>18/07/2023</b>	3.1.2 revised	TC	BD	K
<b>04/04/2024</b>	New blower specs	MU	TC	L
<b>21/08/2024</b>	Scour removed	RT	TC	M
<b>08/05/2025</b>	Activated sludge removed	RT	AB	N
<b>03/03/2026</b>	H&S sections revised	TC	AB	O

## WCSEE T300

### 1. SAFETY

It is extremely important that maintenance procedures in this document are followed. Any deviation from this could cause serious injury or have a detrimental effect on its operation.

#### 1.1. Health and safety at work act 1974

Section 6a of the act requires manufacturers to advise their customers on safety and handling precautions to be observed when operating, maintaining and servicing their products.

The user's attention should be drawn to the following:

- All sections of this manual should be read before undertaking work on the equipment.
- Suitably trained personnel must carry out the installation.
- Normal Health and safety precautions must be taken and appropriate procedures observed to avoid accidents.
- Refer to WCSEE Ltd for further technical advice or product information.

#### 1.2. General health and safety

The layout of the WCSEE LTD T300 tanks have been laid out to ensure that health and safety on site is optimised in line with designer duties specified by the CDM regulations 2015. It will be safe manner, and agrees with comments from the principal designer. Lone working in, and around the plant should be prohibited.

#### 1.3. Leptospirosis

The following is extracted from a health warning card issued to WCSEE LTD staff. It is the client's responsibility to ensure that the relevant Personal Protective Equipment (PPE) is available and used.

There are two types of Leptospirosis that effect people in the UK and they are as follows:

- Weil's disease, which is a serious infection transmitted to humans by contact with soil, water or sewage that has become contaminated with urine from infected rats.
- Hardjo-type Leptospirosis, which is transmitted from cattle to humans.

The typical symptoms for both diseases start with a flu like illness, with a persistent and severe headache, muscle pains and vomiting. Jaundice generally appears on the fourth day of the illness.

The bacteria can enter your body through cuts and scratches or through the lining of the mouth, throat and eyes.

**1.4. Sensible Precautions**

After working with contaminated fluid or other materials it is important that hands and forearms are washed thoroughly with soap and water. If your clothing or boots become contaminated, then they should also be washed immediately after use.

Immediate action should be taken, so that any cuts scratches or abrasions are washed thoroughly with clean water, prior to applying any protective covering (plaster or bandage).

Do not handle food, drink or smoking material without first washing your hands. If you display any of the symptoms described after coming in to contact with sewage; report to your doctor immediately advising them of the circumstances.

**1.5. Vaccinations**

To avoid the possibility of illness it is recommended that all site personnel have the following vaccinations. WCSEE Ltd also recommends that you that you consult your doctor for any additional vaccinations that you may require. The general vaccinations WCSEE use for all personnel are as follows:

- Hepatitis A
- Hepatitis B
- Polio
- Tetanus
- Typhoid/cholera – probably carried out as a child.

**2. Warranty**

WCSEE Ltd will provide the following warranty to the items listed below:

**Note:** warranty period will be active from the day, from which the tanks are positioned on the base slab, or passes on to the customer's premises/construction site.

**2.1. T300 tank enclosures**

WCSEE Ltd will provide a 12 month warranty period for the external & internal structure of the tank.

**2.2. M&E installation**

WCSEE LTD takes no responsibility for improper storage, or bad installation/maintenance performed by unqualified personnel. This also covers the overloading of the plates, above that of normal conditions, and any other accidental cause, or disregard for the information in this document.

**2.3. Warranty limitations and exemptions**

WCSEE Ltd shall not be liable for any labor involved for the removal or replacement of its equipment or the subsequent transportation, handling or packaging of any part or parts thereof. In no case will WCSEE Ltd be liable for loss incurred because of interruption of service or for consequential damages, labor or expense required to repair defective units, nor shall this constitute a cause for the cancellation of the contract of purchase and sale. Specifically exempt from this warranty are limited life of consumable components subject to normal wear and tear.

**2.4. Chargeable non warranty work**

Service charges will be incurred (including parts and labour), due to the following:

- Unauthorized alteration.
- Accidental damage, caused by plant or movement on site outside of WCSEE's control.
- Improper use.
- Abuse.
- Tampering.
- Failure to follow installation instructions or failure to follow operating and maintenance procedures.

The above will not be covered by this warranty. All service visits for non-warranty work are chargeable at the standard engineer day rate plus mobilization. This warranty gives specific additional benefits. Statutory rights are unaffected.

**Note:** WCSEE LTD will not uphold the guarantee on the purchased equipment if the routine maintenance has not been performed and documented.

WCSEE LTD strongly recommends that the installation of the purchased product is carried out by a qualified and experienced installer. Dependent on the site a suitably qualified civil engineer may need to be consulted for the construction of suitable base slab to support the imposed load.

### **3. Risk assessment**

#### **3.1. Introduction**

This section of the manual is intended as a guide and as such does not cater for every situation encountered on site. WCSEE assumes that the necessary permissions have been granted prior to the installation of the plant. It is also the assumption that working methodology abides by the Health and Safety at work act and that all civil engineering design is undertaken by a chartered Civil Engineer.

Please ensure that due consideration is given to the following:

#### **3.1.1 Installation Design Considerations**

- Planning permissions & Building Regulations and other regulating or interested parties.
- Environment Agency consent to discharge.
- The size of the plant relevant to the number and type of people that will be using it, e.g. domestic, light industrial, etc.
- Costs, legal implications and siting in consideration to shared systems.
- The whereabouts of wells, boreholes and springs used as sources of potable water; existing non-mains sewerage systems and soakaways; water courses, ponds and lakes and designated protected areas.
- The whereabouts of other services, pipes, cables and ducting.
- Local ground conditions. Is specialist knowledge of civil engineering required, catering for specific ground condition requirements?
- The water table at the time of installation - specialist knowledge is required when installing in an excavation that allows water to enter.
- The water table in winter - Special consideration should be given to installations that will be subject to high water table pressure or flood conditions. The treatment plant will need to be installed so that it cannot "float" out of the ground and provision made for continued discharge of treated effluent, should the discharge pipework/soakaway be under water.

### 3.1.2 Installation and positioning

- **Siting** - The plant must be sited within 30m of heavy vehicle access for draining. The plant should, where possible, be sited above the high-water table mark and above or beyond the flood plain. See items above and accompanying note. The plant should be sited as far from the habitable parts of the dwelling as possible. Many local authorities recommend 10m as a minimum, but easements are possible for smaller sites.
- **Electrical supply** – If the plant has been equipped with a pumped de-sludge option, a qualified electrician should only undertake electrical installation. A safe and reliable power supply is required at all times, as the pumps are required to de-sludge at intervals 24/7. Adequate means of power failure indication should be provided. This can be an audible or visual alarm or by regular manual checks.
- When supplying power to the kiosk unit via a 32A, 5Pin Socket, it is advised that the power source is protected with an RCBO supply. If an RCBO is not available, the power cable feeding the kiosk should be hard-wired into the control panel by a qualified electrician.

**Note:** Due to the health risks associated with raw sewage, WCSEE recommend that the treatment plant is not used until the system is complete, commissioned and is operating in a stable manner.

### 3.1.3 Maintenance

- The legal responsibility for the plant as far as operation and maintenance and on-going discharge is concerned.
- Electrical supply: a qualified electrician should undertake the electrical installation.  
A reliable power supply will be required at all times, so an indication of power failure will be required, which can be audible or visual.
- Any visiting personnel should report to the site office and acquaint themselves with the specific site health and safety protocol.
- Before carrying out any maintenance or installation on the equipment it should be electrically isolated, unless a trained electrician is carrying out specific checks under controlled conditions. When performing works of this nature, warning signs should be erected to alert others of the works in progress.
- For all works, risk assessments and method statements will be required to carry out work on site. These should identify the method of work and the risks associated.
- Temporary barriers and warning signs should be erected around any open covers or manholes as appropriate, in particular warning of deep water in the tanks.
- See section 7 for routine maintenance.

#### 4. Introduction

The process used within the WCSEE biozone has been developed to meet the more stringent discharge consents now being imposed by the Environment Agency, particularly with reference to low ammonia levels. The biozone can achieve ammonia standards better than 10mg/L.

The T300 and T3HP (for Hire Use) has been designed for above ground installation only.

The T300 is equipped with an optional access ladder and handrails, where as the T3HP does not require any top-level access. This is shown in more detail in the next pages.

Blowers and controls to provide the air are housed in a separate standalone kiosk adjacent to the plant. The tank and kiosk are manufactured in GRP for corrosion resistance and long life.

*\*As these units are above ground and generally receiving pumped flows, it is therefore necessary to provide suitable flow control before the effluent is received by the unit.*

*The plant should receive Dry Weather Flow as stated in the relevant quotation or design documentation; ensuring adequate hydraulic retention time for the relevant biological processes to take place.*

WCSEE advises the following for lifting practices for the T300 & T3HP tanks:

##### **Checks:**

- Inspect all lifting points and tension if required with a suitable tool.
- The unit must be hoisted empty of all material and fluids.

Test lift the unit to check that the centre of gravity of the unit is in the correct location (See drawing supplied by WCSEE LTD), and that all of the chains are taut. It is critical to ensure a balanced lift, but if in doubt don't lift the tank.

#### 4.1. T300 Tank – Showing Top Level Access

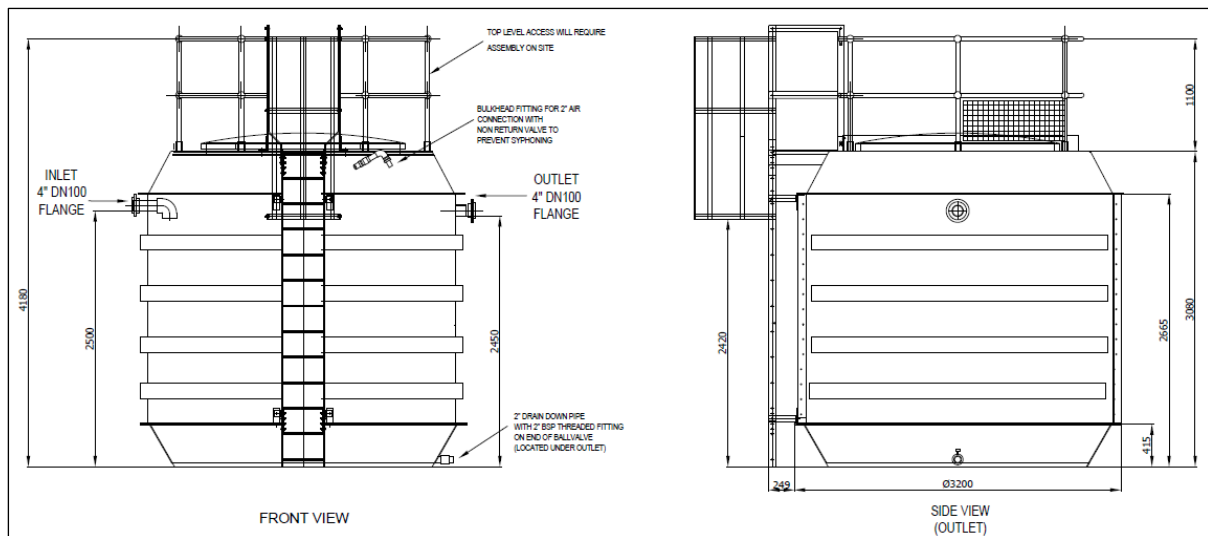

Drawing above shows a T300 with top level access.

(This can be supplied without top level access).

10m of 2" High temperature air hose is provided to connect the blower process air to the tank.

#### Connecting the air hose to the Kiosk

- 2" hosetail connection mounted on the manifold within the Kiosk enclosure. Use Mega clamps which are provided.

#### Connecting the air hose to the Tank

- 2" hosetail high level connection mounted to the top side of the tank. Use Mega clamps which are provided.

#### 4.2. T3HP Tank – For Hire

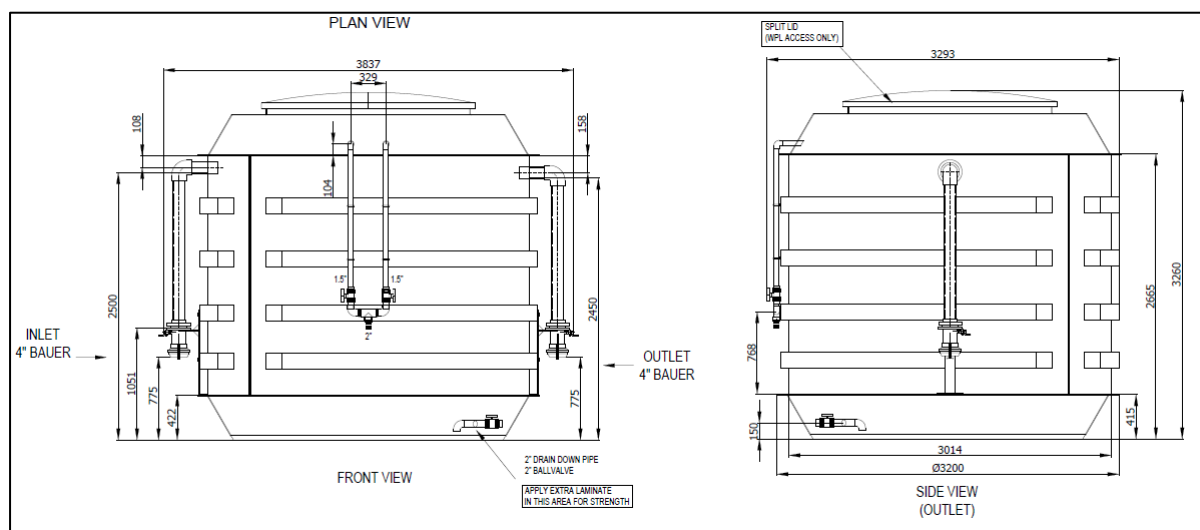

Drawing above shows the Hire Asset T3HP with low level 4" Bauer connections to both the Inlet & Outlet. No top-level access is required with this arrangement and the unit comes equipped with a lid for access by WCSEE only.

10m of 2" High air temperature hose is provided to connect the blower process air to the tank.

#### Connecting the air hose to the Kiosk

- 2" hosetail connection mounted on the outside of the Kiosk. Use Mega clamps which are provided.

#### Connecting the air hose to the Tank

- 2" hosetail low level connection mounted to the side of the tank. Use Mega clamps which are provided.

## 5. PLANT OPERATION

The plant is designed to operate continuously with the minimum of maintenance after it has been commissioned. The plant will provide effluent within the designed discharge consent standard after an initial start-up period, of 4 to 10 weeks depending on the water temperature and site conditions.

**\*It is important that the sewage-input conditions are kept within the plant design criteria. Refer to section 8. Start Up Procedure.**

Both the T300 Tank and the Hire T3HP come with duty/standby blowers, (3.45kW, 6.7A, 3 phase, IE3). The blower operates continuously to provide air for the biological process in the filter section.

**Note:- The T3HP Hire Kiosk comes equipped with an external 3ph, 32A 5-pin socket, mounted to the outside of the Kiosk. This allows for an easy and fast installation.**

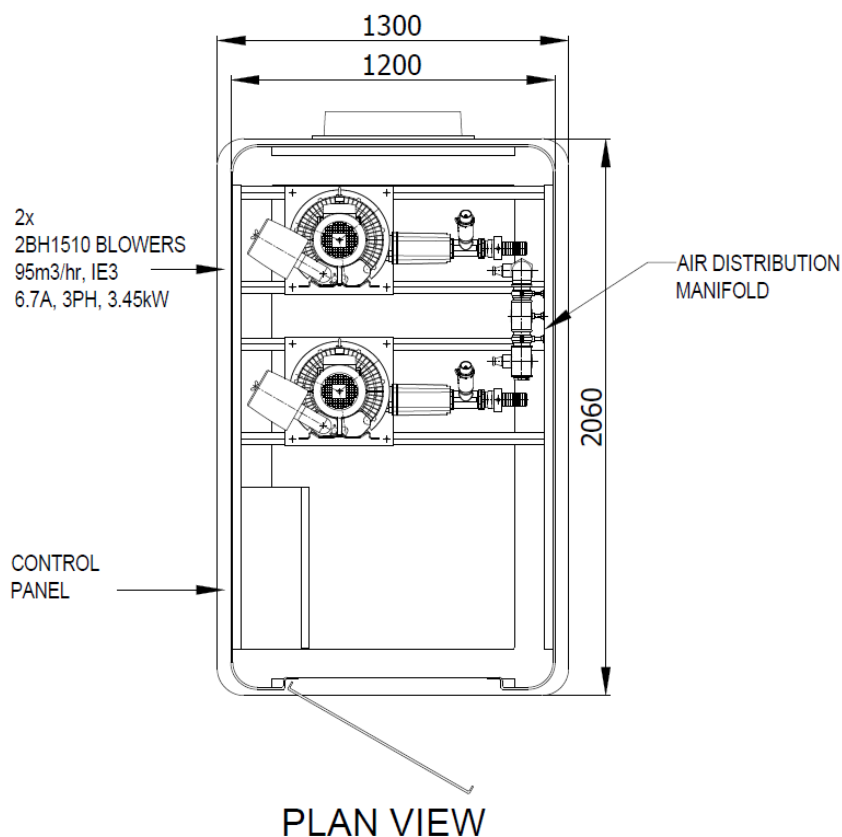

### 5.1. **TIMER (applicable to 2023 models tanks)**

There is a timer positioned inside the control panel on the back side of the door. It is to reduce the power consumption by turning off and on the blower(s) in 15min intervals, during normal operation. (Note:- the Blowers should be running 24/7 for the first 6-8 weeks or until the plant is fully seeded).

Only the site operator should adjust the settings.

#### **5.1.1. Timer Set Up**

To set up the timer, follow the below steps:

- Selecting the "A" letter on the bottom left of the timer, means the timer is in the "Auto" position. (As indicated in Picture 1 below). This set-up will allow the timer to be in operation.
- When the main switch (located on the front of the control panel) is in the "Auto" position, the low air pressure switch will be automatically inhibited to OFF for a certain period of time when the blower stops, so the beacon will not flash showing a fault.



Picture 1

- On the Timer, Once the "Auto" mode is selected, select the cycles required for the blower ON/OFF times. This will be done by moving the switches from the circle of yellow tabs to the outwards position for ON and the inwards position for OFF (see Picture 2 below).
- The Initial set-up is for 15min OFF and 15min ON. If the quality of effluent is deteriorating, increase the blower ON time by moving more yellow tabs to the outwards position.

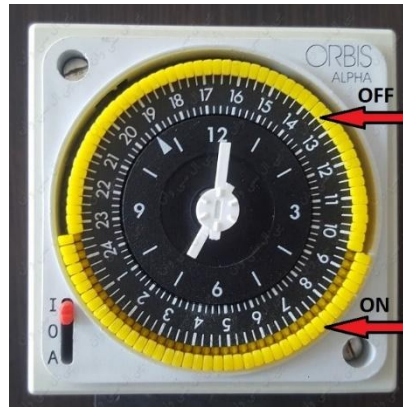

Picture 2

- On the Timer, selecting the letter "I" on the bottom left of the timer mode will run the blower in manual setting, (as indicated in Picture 3 below).



Picture 3

- On the Timer, selecting the letter "O" on the bottom left of the timer, will switch the blower OFF and no air will go to the plant, (as indicated in Picture 4 below).



Picture 4

**5.1.2. General Requirements**

All timers retrofitted in existing panels must be installed by WCSEE, or the process of the sewerage treatment plant will not be guaranteed by WCSEE.

On factory fitted timers, a visit is required after 2 months in operation to check the D.O. (Dissolved Oxygen Levels) and to visually inspect the effluent.

**5.1.3. Electrical Connections**

Below shows the electrical details of the timer controls.

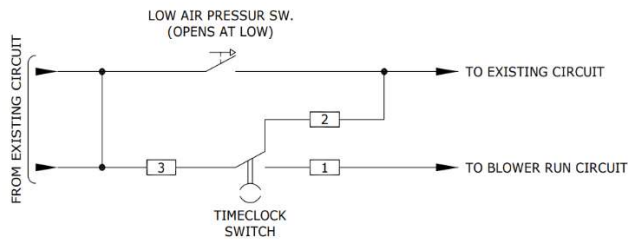
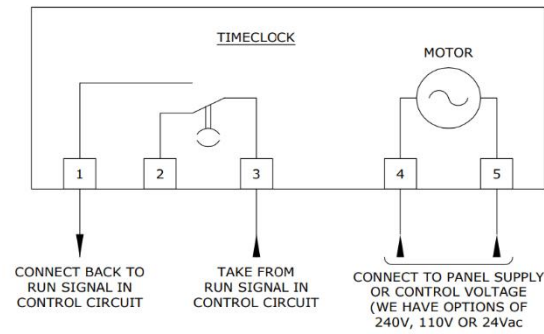

## 6. ROUTINE MAINTENANCE

### 6.1. Weekly

- Check that there is noise coming from the kiosk indicating that the blowers are operational.
- If a warning alarm beacon is fitted it will flash to indicate a lack of air to the plant.

### 6.2. Six Monthly

Carry out the weekly check plus:

- Open the Kiosk and check the extract fan, if fitted, is operating and that the blower and control panel are dry and in good working order.
- (If the tank is supplied with top level access) open the Lid on the main unit and check that there is an even distribution of air around the filter indicated by an even distribution of bubbles on the surface of the filter sections.
- Check that the blower air filters are clear and knock off any collected dust or replace if necessary.
- On the T3HP Hire Unit, the air diffusers for the biozone are split into two zones. In normal operation the air feeds both zones, but both can be isolated (not at the same time). Every 6 months, 1 zone can be isolated for 1 hour followed by the second zone for a further hour so to ensure there is no build-up of unwanted biomass on the media.

### 6.3. Annually

Carry out the monthly checks plus:

- Thoroughly check all the plant. If there is any scum or grease build up on the sides of the tanks or fittings this should be removed by pressure washing or removed with a wood or plastic scraper. DO NOT USE A METAL SCRAPER.
- Check the control panel, fan inlet filters and blower(s) for correct operation and service or replace as required.
- Check the air distribution over the filter surface (if required). Safe temporary access will need to be erected.

## 7. PROBLEM SOLVING

### 7.1. Poor Effluent

Blower not running	Refer to 7.2
No Air bubbles in filter chamber	Refer to 7.3
Poor air distribution	Refer to 7.6
Poor flow control	Refer to site

### 7.2. Blower not Running

Symptoms	Corrections
Power cut	If temporary (24/48 Hours) do nothing. If extended, obtain alternative source of power or tanker sewage away. Important: on power being returned to three phase supplies check for correct rotation of blowers
Power supply fault	Switch off blowers check fuses and any RCD breakers, on 3-phase supplies check for correct rotation. Switch blowers to on and the blowers should start. If not switch off and call electrician.
Blower overload has tripped	Check for any obvious causes, reset overload and switch to on. Blowers should start, if not switch off and call an electrician.
Blower runs intermittently	Check that the cooling fan is running and the air ducts are clear, as overheating in the cabinet will cause the high temperature trip to switch off the power to all but the fan and beacon if fitted. Replace fan if it has failed. Temporary solutions if the weather is fine: leave the kiosk door open but ensure that no one can gain access to electrical or rotating mechanisms.

### 7.3. No air bubbles showing on the surface of the filter section

Symptom	Corrections
Blower not running	Refer to 7.2
Blower running	Check all valves are open in the kiosk and main unit. Check that the airlines are not broken or leaking. Find where the air is escaping from pipe work and repair. Check inlet filter(s).

### 7.4. Blockages

Symptom	Correction
Level in sections is higher than normal	If the plant has been flooded due to high water level or other cause the 'V' notches may have become blocked these should be cleared of any debris the material should be returned to the primary settlement tank.

7.5. Smell

Symptoms	Corrections
Smell escaping from the covers on the plant	If venting is via the inlet pipework, ensure that the outlet T-vent is closed and the inlet T-vent is open. If venting is via the outlet pipework, ensure that the inlet T-vent is closed and the outlet T-vent is open. Also check the seals around the covers and reposition as necessary.
Smell escaping from the kiosk	Check that any ducts to the plant (holding tank or pump chamber if installed) are sealed with expanding foam.
Plant smells	Check that grease has not entered the treatment plant. Do all the 'Annual Checks'.

7.6. POOR AIR DISTRIBUTION OVER THE FILTER SECTION

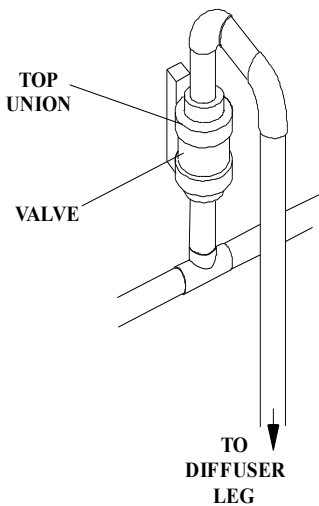
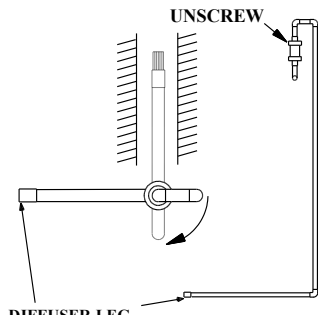
Cause	Correction
<p>Blocked air Diffusers <b>(NOT relevant to the T3HP Hire Unit)</b></p>  <p>The diagram shows a vertical pipe assembly. At the top is a 'TOP UNION' which connects to a 'VALVE'. Below the valve is a vertical pipe that turns 90 degrees to become a 'TO DIFFUSER LEG' pointing downwards.</p>	<p>Turn off all but one of the air diffusers at the valves. Then proceed to check the one that is on for the position of bubbles. The increased pressure should clear any blockage in the diffuser. If not the diffuser can be removed by switching the air supply (blower) off and disconnecting the diffuser tube at the top of valve, turning through 90° and lifting up through the diffuser access slot. On early units the diffuser is screwed into the fitting on the end of the tube and can be removed for cleaning or replacement. Later units have a cap with a 5mm hole in the end. In addition there are also some cross holes on some of the horizontal pipe. Clear all holes.</p>  <p>The diagram shows a horizontal pipe with a vertical cap. An arrow labeled 'UNSCREW' points to the cap. Below the pipe, a 'DIFFUSER LEG' is shown at an angle.</p> <p>Repeat as required for any other suspect blocked diffusers, and then move the air diffusers by angling the tube as required to improve air distribution.</p>
Filter media partially blocked by excessive biomass	This indicates that the plant is overloaded, check design loading and contact WCSEE for advice.
Filter media partially blocked with sludge	This indicates carry over from primary tank, check sludge levels and de-sludge if required. Also check for excessive flow possibly due to ground water ingress into foul sewer.

## 8. PLANT START UP

For commissioning, carry out the six checks as stated in this manual. The plant should then be left running as normal. It takes time, depending on the temperature, for the plant to grow a stable biomass when it is first started up. This is 3 to 6 weeks for the process to start reducing the BOD. It then takes another 4 weeks for the process to start reducing the ammonia.

### 8.1. Introduction

The bacteria necessary to provide the biological oxidation are present in normal sewage and will rapidly multiply if given the right conditions. The process breaks down most of the sewage into carbon dioxide and water.

There are two main types of bacteria:-

- a) Carbonaceous bacteria which, as the name suggests will break down the carbon based solids.
- b) Nitrifying bacteria which break down the ammonia to nitrogen, and this will be partially converted to nitrogen gas before being discharged.

The carbonaceous bacteria are more prolific and also less prone to damage by chemicals (cleaning agents) than the nitrifying bacteria. Both are adversely affected by low temperatures or low pH which may be found in soft water areas. The nitrifiers are more critical and cease to be effective in temperatures below 10°C or pH below 7. Low temperatures are not normally found in domestic sewage, this will rarely drop below 15°C unless the pipe runs are very long or the flow very small.

The right conditions to grow bacteria are to have both oxygen and food available and these conditions are found in the Submerged bed aerated filter section of the HIPAF

The effluent quality is defined by a group of two or three figures as BOD:SS: NH<sub>3</sub> (Biological Oxygen Demand: Suspended Solids: Ammonia) All figures represent the concentration in ppm( parts per million) and the most usual requirement is 20:30 with no Ammonia standard. If the discharge point is very sensitive the standard may be as tight as 10:10:5

## 8.2. Start Up

It is very important that the air blowers are switched on BEFORE any sewage is allowed to flow into the Aerated filter section.

As soon as sewage is introduced into the tank to provide flow, the bacterial action will commence. The carbonaceous break down will start almost immediately which will produce large quantities of foam. Although the process will have started the initial quality of the effluent will initially be poor with little treatment.

## 8.3. Procedure

1. Switch on Blower(s) and check that air distribution is correct are working.  
***IMPORTANT:- on blowers with 3 phase motors check for correct rotation BEFORE CONNECTING THE HOSES TO THE BLOWER(S)***
2. Introduce sewage into the tank at the design rate.
3. Check after 12 to 24 hours that:-
  - I. Blower(s) are running correctly and not overheating
  - II. Air distribution in the Filter section is correct and that foam is being produced

There is no further intervention required once the plant is in operation.

## 9. Decommissioning and transportation

The decommissioning of the unit prior to transportation is a critical procedure. **No** attempt should be made to move the unit until decommissioning has taken place.

1. Disconnect the supply of sewage to the unit.
2. Introduce a supply of fresh water, if available
3. Continue running the blowers
4. During this time the biomass will gradually die off with the fresh water passing through the unit
5. Continue this operation for a minimum period of one (1) week to ensure all the biomass is removed from the media.
6. Drain down the unit, ensuring residual faecal matter is cleaned from the exterior of the unit
7. Continue running the blower for a further 2 days to dry out the media
8. Turn off the blowers and disconnect associated equipment

**Under no circumstances should the unit be lifted with water in, or before the biomass has been flushed out.**

[info@wcs-group.co.uk](mailto:info@wcs-group.co.uk)  
[wcs-group.co.uk/environmental-engineering](http://wcs-group.co.uk/environmental-engineering)

**Disclaimer**

WCS Environmental Engineering (WCSEE) has a policy of continual product development and the above information may be subject to change without notice. WCSEE reserve the right to to change the specification in line with company policy of improvement through research and development. Errors and omissions excepted. Models shown in this manual may include additional cost options that are not part of the standard specification